

AUTOMATIC GRINDING

Suzhou Goodwill Machinery Equipment Co., Ltd.

Add: No. 21 Xiexin Road, New District, Suzhou City, Jiangsu Province, China.

Tel: +86-0512-65580060

Email: info@goodwillme.cn

Web: www.goodwillme.cn

SERVICE SUPPORT SYSTEM

TECHNICAL SUPPORT

With a strong technology platform, Goodwill provides users with professional technical support for pre and after-sales of industrial intelligent integrated systems, including intelligent integrated system design, simulation, installation and commissioning, maintenance and rectification, and expansion of intelligent integrated systems, upgrades and transformations.

Goodwill specifically provides professional services and technical guidance in the field of intelligent Grinding.



TRAINING CENTRE

In terms of user training, Goodwill engineers have years of practical experience in the field of application, and can provide you with basic training and intensive on-site installation training, sharing technical knowledge and application experience. In addition to standard training courses, Goodwill can also provide different levels of advanced and customized training services according to your specific needs.



SPARE PARTS SUPPLY

To cater for equipment maintenance and repair, Goodwill has a large inventory of original parts, ensuring that every original spare part can realize the normal use of your equipment, thereby optimizing, updating and extending the service life of Goodwill products. Not only that, in terms of control software, Goodwill will continue to provide you with professional after-sales service, and kits such as installation and maintenance kits and upgrade kits at any time to realize equipment modification and the upgrading of new functions.



Foundry Factory Automation Solutions –

Goodwill's forward-looking thinking sets and leads the pace of enterprise innovation, and integrates a series of intelligent one-stop solutions for foundries in response to a series of problems such as low labor efficiency, unstable product quality and serious environmental pollution. From the data collection and tracking in the production of raw materials into the warehouse, to the fine grinding in the cleaning process, and finally to the 3D visual inspection before the product is shipped out of the warehouse, the automation system runs through every link in the production, and finally realizes high quality, high processing efficiency and environment, and a zero-pollution modern intelligent enterprise.

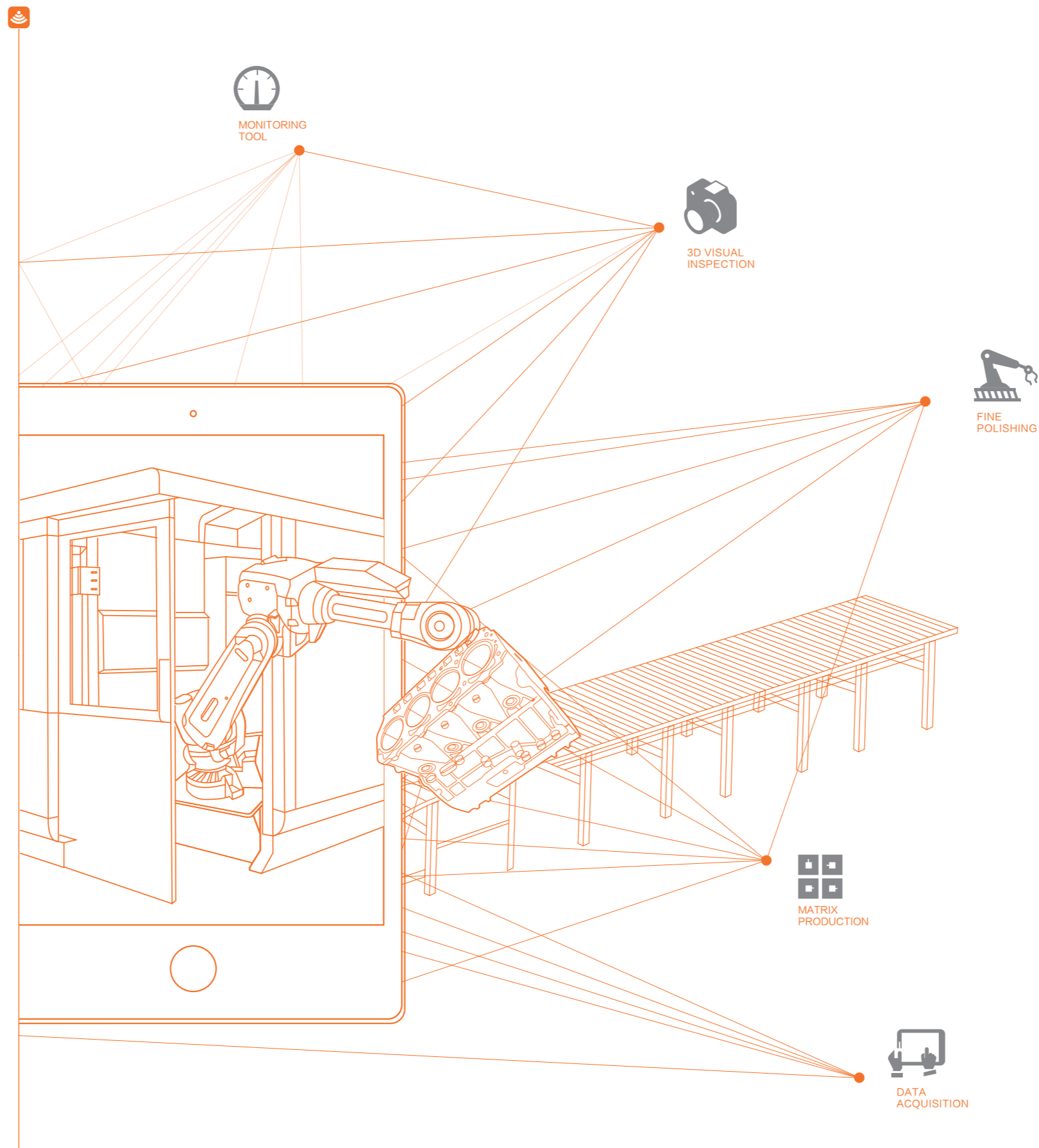

Intelligent Grinding Production Line - Grinding Experts, Professional Customization

In the field of automated grinding, Goodwill 's independent innovation technology, customizes professional and intelligent solutions for different industrial manufacturing dilemmas and needs. Whether it is a separate grinding machine or a complete grinding line, it can maintain the consistency of the production parts and the efficiency of grinding, helping the company to build a perfect intelligent production line.

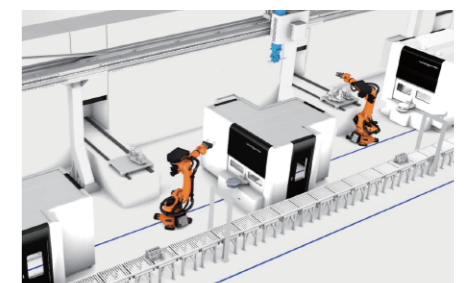

GJ40E

Smart Grinding Machining Center



It is suitable for casting of crankshafts, exhaust pipes, turbine housings, steering knuckles, etc.

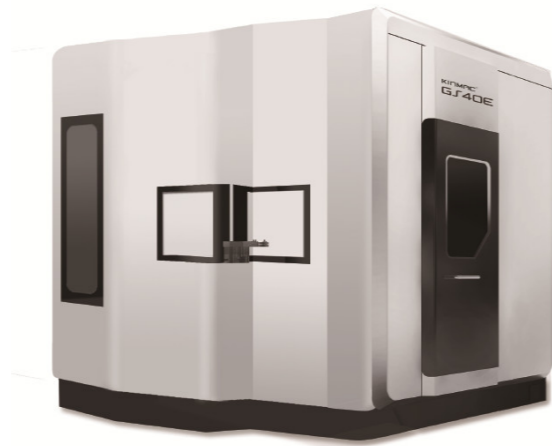

The maximum height of the part	250mm	[including fixture]
The maximum weight of the machined parts	40Kg	[including fixture]
Maximum turning diameter of workpiece	ø400mm	

GJ80E

Smart Grinding Processing Center



It is suitable for small engine block, cylinder head and other castings grinding; successful application of well-known Chinese enterprises.



The maximum height of the part	250mm	[including fixture]
The maximum weight of the machined parts	250Kg	[including fixture]
Maximum turning diameter of workpiece	ø800mm	

KINMAC®

KINMAC®

GJ70E

Smart Grinding Machining Center



It is suitable for grinding of castings such as exhaust pipe, turbine casing, caliper body, reducer housing, crankshaft and steering knuckle.



The maximum height of the part	400mm	[including fixture]
The maximum weight of the machined parts	100Kg	[including fixture]
Maximum turning diameter of workpiece	ø750mm	

GJ120E

Smart Grinding Processing Center

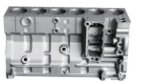

It is suitable for casting of cylinders, cylinder heads, etc.; the world's top 500 companies successfully application.



The maximum height of the part	500mm	[including fixture]
The maximum weight of the machined parts	400Kg	[including fixture]
Maximum turning diameter of workpiece	ø1200mm	

CS55

' Smart Grinding And Cutting Machining Center



It is suitable for cutting and grinding castings such as exhaust pipe and turbine Housing; it has been successfully applied by famous Chinese large casting enterprises.

The maximum height of the part	400mm	[including fixture]
The maximum weight of the machined parts	60Kg	[including fixture]
Maximum turning diameter of workpiece	ø550mm	

GDT210

' Smart Double Robot Grinding

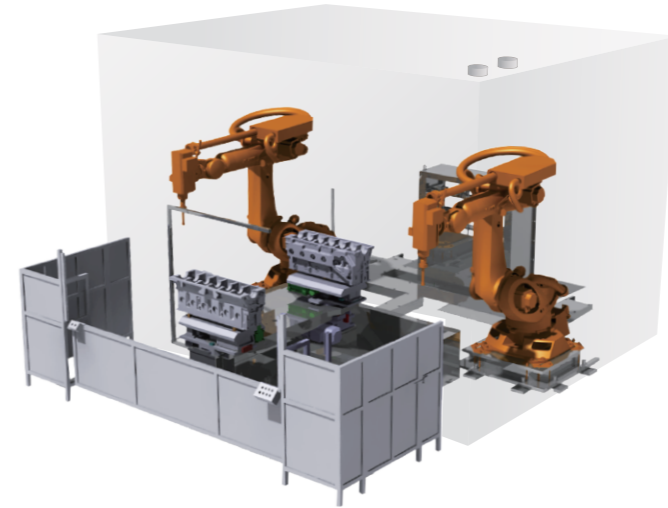
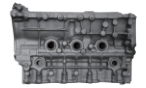

Maximum diameter of the casting	1200mm	
The maximum weight of the machined parts	400Kg	[including fixture]

It is suitable for grinding of large weight castings such as cylinder block and cylinder head; successfully applied by well-known engine enterprises in China.

KINMAC®

KINROBOTICS®

T60

' Pass-through Grinding Center



It is suitable for grinding of brake discs, brake drums, etc.; successful application of Chinese well known company.

The maximum height of the part	300mm	[including fixture]
The maximum weight of the machined parts	100Kg	[including fixture]
Maximum turning diameter of workpiece	ø485mm	

GT210

' Single Robot Grinding Cell

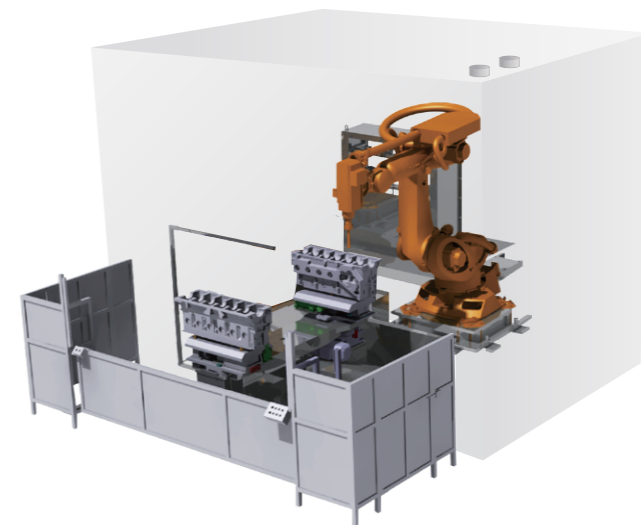

Maximum diameter of the casting	800mm	
The maximum weight of the machined parts	300Kg	[including fixture]

It is suitable for any casting.

KINEYE® 3D Machine Vision, Starting With The World

The KINEYE® 3D machine vision system jointly developed by Goodwill and European research institutes has the technical level of the world of shoulders, enabling intelligent reform and upgrading of manufacturing lines, helping companies to produce at higher speeds and lower costs, eliminating defective products, thereby enhancing the competitiveness of the enterprise market.

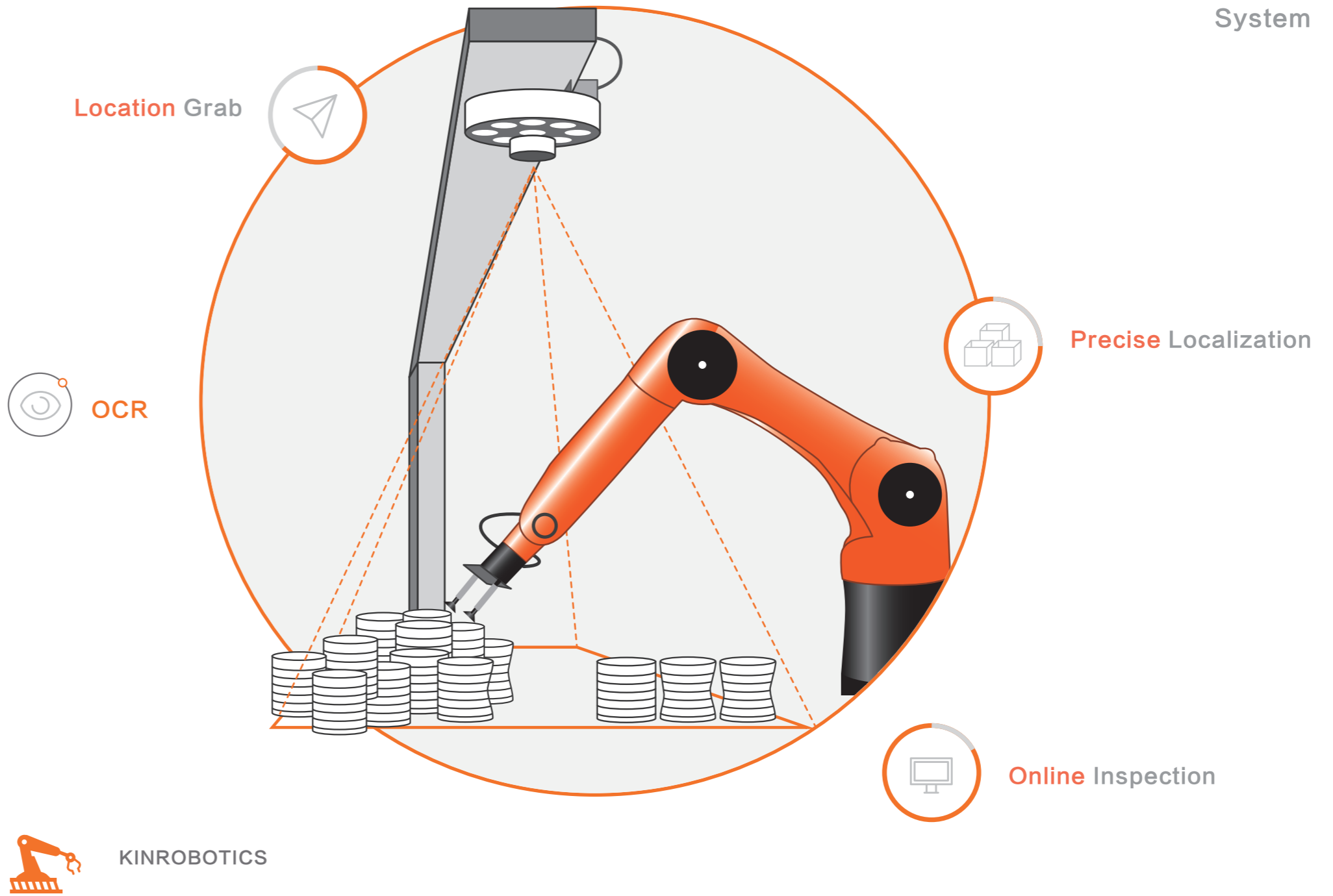
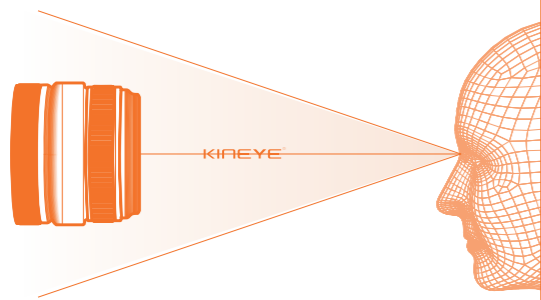

3D
Machine
Vision
System

Bin Picking



KINEYE® 3D machine vision system can identify messy and disorderly targets and objects, accurately obtain the position information of the work piece, and realize precise positioning and fast capture of the robot or robot arm. The system can be widely used in material handling, assembly, racking and lowering of various production lines.

Movement Capture

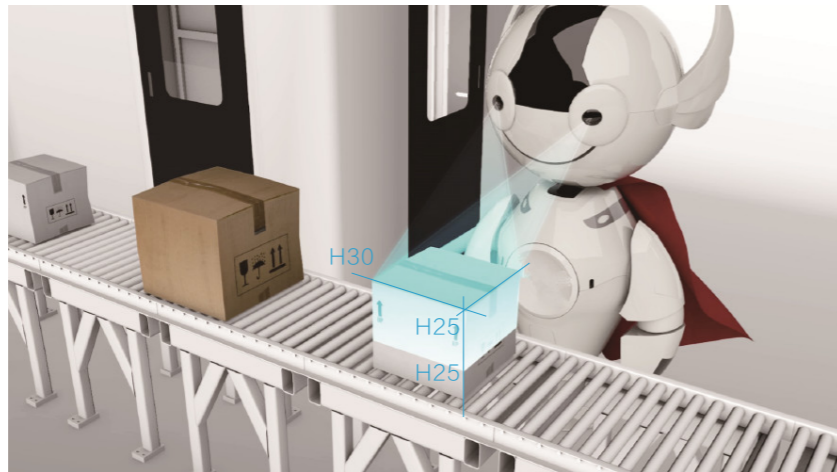

The KINEYE® 3D machine vision system uses state-of-the-art 3D vision positioning technology to accurately predict and accurately capture moving targets on the track in highly automated manufacturing processes based on the 3D feature information of the work piece. The whole process does not require the moving targets to stop.



The robot with 3D vision system, uses 3D machine vision to process, analyze and understand the image to identify the targets and objects of different modes, thus guiding the grinding robot to complete the grinding operation of the target object.

Guide The Robot To Grind

External Detection

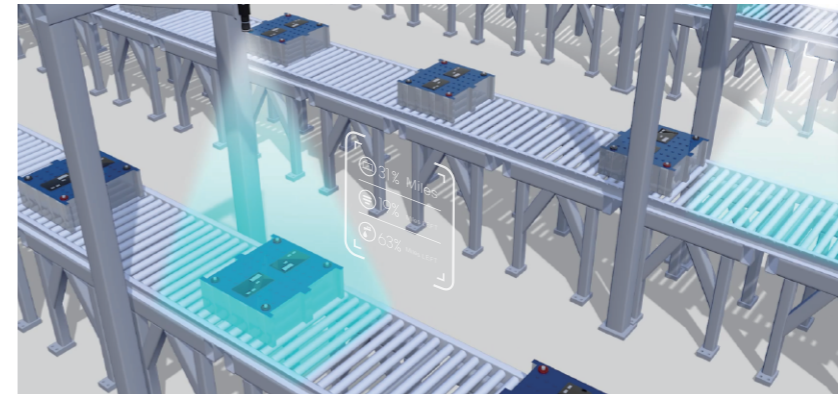

Thanks to the binocular simulation of the human eye design, KINEYE® 3D machine vision can easily perform spatial level detection, that is, accurate measurement of complex product size and defects, not only completely replacing manual tasks, but also operating with more accuracy and efficiency.

DIAMOND GRINDING TOOLS



GRINDING



CUTTING



DEBURRING

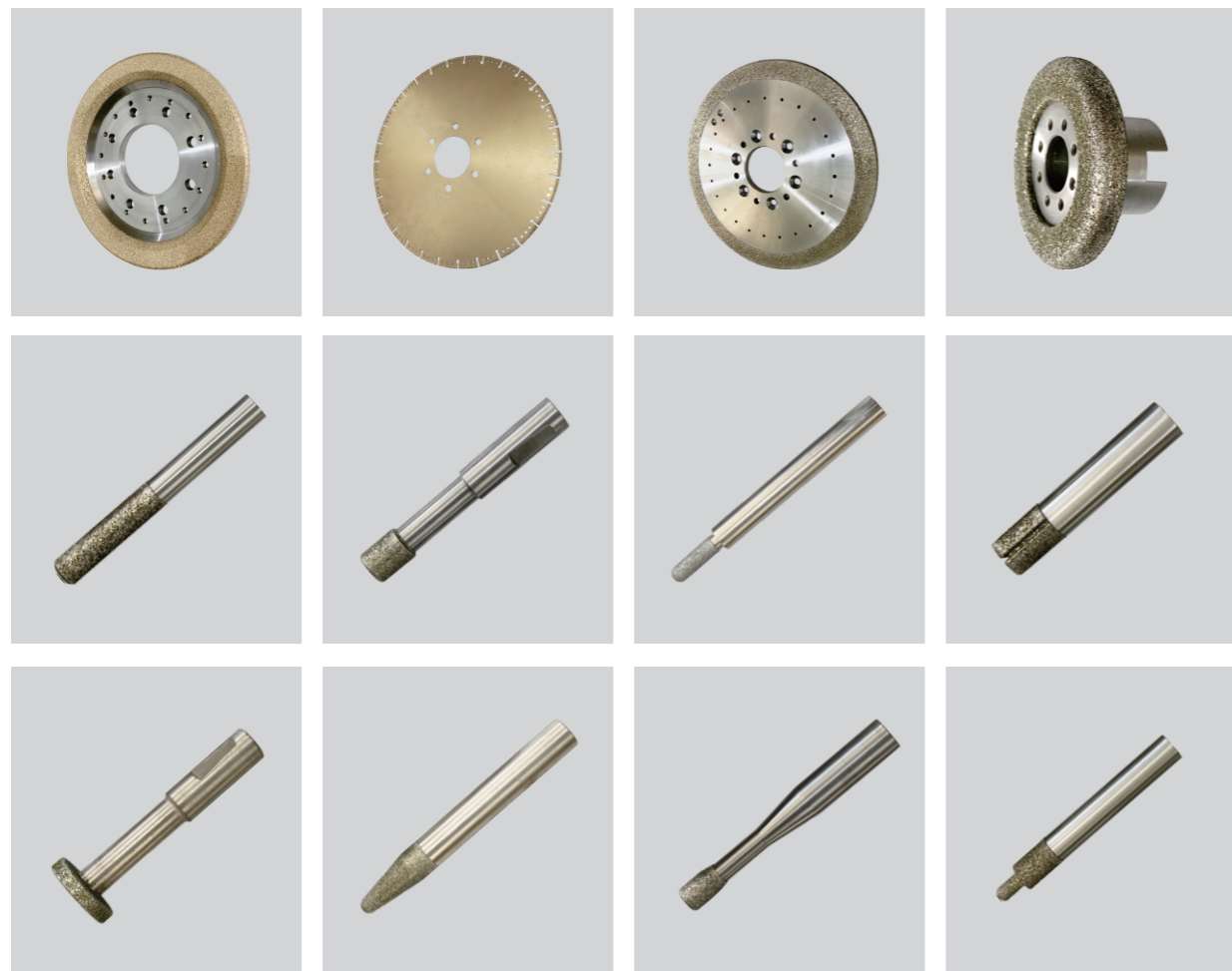

KINFMS Flexible Manufacturing System - Intelligent Integration, Efficient Production



Developed and used independently by Goodwill, the flexible production management system KINFMS (Flexible Manufacturing System) is integrated by CNC machine tools and other automatic process equipment, supported by the computer information control system and material automatic storage and transportation system for centralized management of plant production lines and equipment. KINFMS intelligently manages the resources, production, warehouse, quality and other modules, and connects with ERP or heterogeneous systems, so that the production links and equipment are closely linked to form an efficient operation system.

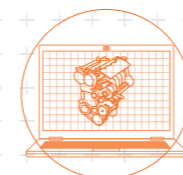
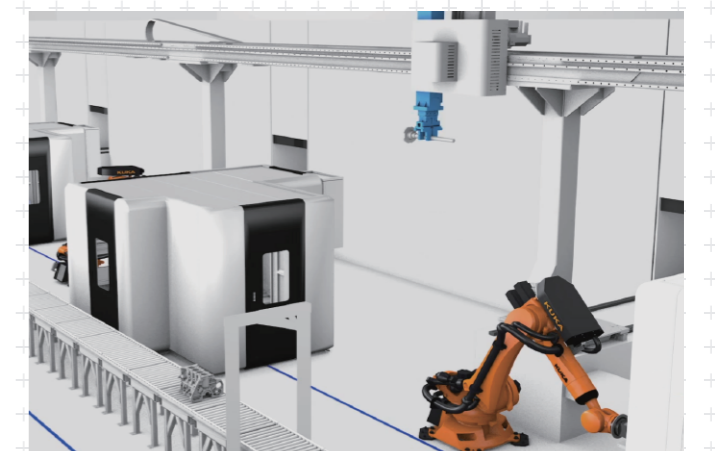

Flexible Intelligent Grinding Center



The flexible intelligent grinding center is composed of core products such as intelligent grinding machine, robot, central material warehouse and 3D machine vision system. The complete product chain provides a solution for flexible manufacturing. Through software docking management platform and production execution hardware, we control all aspects of the management Grinding machines in an all-round way, and build an insurmountable technical barrier.

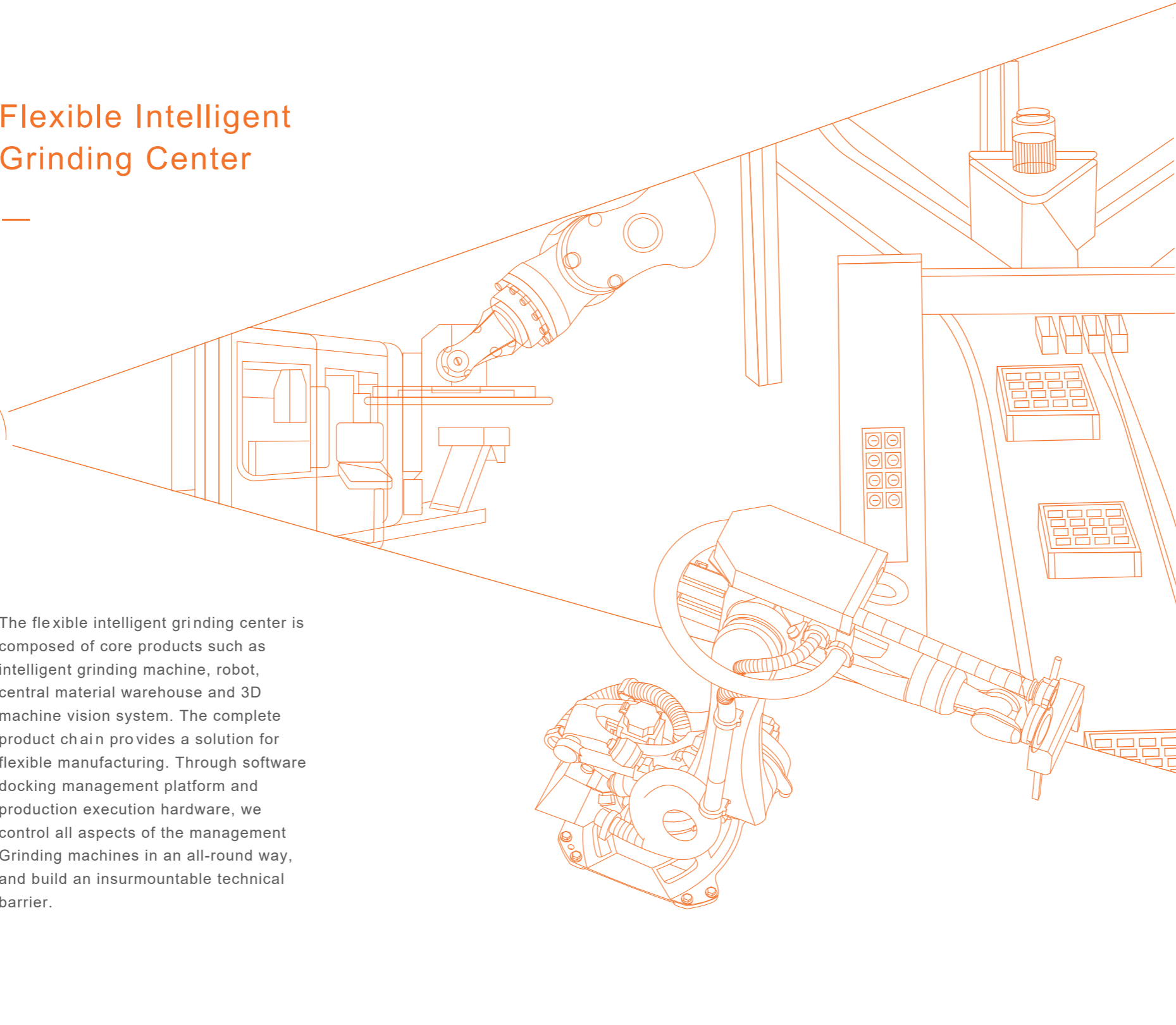

Automatic Loading And Unloading

The automatic loading and unloading unit of the machine tool independently developed by Goodwill uses the robot or gantry system to realize the automatic feeding, unloading, transportation and handling, of the machine tool. The process is fully automated, avoiding cumbersome manual operations.

